

X-Gauge

For the smart® fortwo (gasoline/petrol), 2001 to 2006
For the smart® fortwo cdi (diesel), 2004 to 2006

User Manual



Table of contents

1	Important Safety Instructions	3
2	Disclaimer	3
3	Limited Warranty.....	3
4	Definitions of Terms	4
5	Introduction	4
6	Features and Specifications	5
6.1	Non-ECU Parameters.....	5
6.2	ECU Parameters.....	6
6.3	Calculated Parameters.....	7
6.4	Display Modes.....	8
6.5	Diagnostic Trouble Codes	9
6.6	Languages.....	9
6.7	Units.....	9
6.8	Display Intensity.....	9
6.9	Module Specifications.....	10
7	Operation.....	10
7.1	Ignition Off.....	11
7.2	Ignition On	12
7.2.1	Display Mode: Time	12
7.2.2	Display Mode: Main	13
7.2.3	Display Mode: Text	15
7.2.4	Display Mode: Graphic	16
7.2.5	Display Mode: Trouble Codes.....	19
8	Menu	20
8.1	Main Menu	21
8.1.1	Submenu: Mileage Settings.....	22
8.1.2	Submenu: Speed Correction	24
8.1.3	Submenu: Acceleration Settings.....	25
8.1.4	Submenu: Turbo Settings	26
8.1.5	Submenu: Select Display Mode.....	27
8.1.6	Submenu: Set Time.....	29
8.1.7	Submenu: Set Date.....	30
8.1.8	Submenu: Select Units	31
8.1.9	Submenu: Select Language	32
8.1.10	Submenu: Select Greeting.....	33
8.1.11	Submenu: Set Display Intensity.....	34
8.1.12	Submenu: View System Info.....	35
8.1.13	Submenu: Clear Trouble Codes.....	37
8.1.14	Submenu: Factory Reset.....	38
9	Appendices	39
9.1	Default Settings after a Factory Reset.....	39
9.2	FAQ.....	41
9.3	Troubleshooting.....	44

1 Important Safety Instructions

Please read these warnings carefully before using the **X-Gauge** !

- As a driver it's your first priority to handle your vehicle in a safe manner and to pay constant attention to the traffic situations around you. Be aware of the fact that the real-time display behavior of the **X-Gauge** can be highly distracting to a driver. Never adjust the gauge's display mode or any of its menu settings while you are driving your car!
- Because the **X-Gauge** displays a lot of information about the performance of your smart[®] engine, it's easy to recognize when some engine parameter starts to behave abnormally. The **X-Gauge** further helps in diagnosing engine problems due to its capability for retrieving trouble codes from the ECU. However, keep in mind that these features do not permit any deviations from the scheduled maintenance intervals for your car that are set for by the manufacturer.

2 Disclaimer

The information contained in this document is subject to change and does not represent a commitment on the part of the copyright holder. While the information contained herein is assumed to be accurate, Welte Engineering assumes no responsibility for any errors or omissions. In no event shall Welte Engineering be liable for special, direct, indirect, or consequential damage, losses, costs, charges, claims, demands, or expenses of any nature or kind.

3 Limited Warranty

The **X-Gauge** module is warranted against defects in materials or workmanship for the duration of one year from the date of purchase. Welte Engineering will at our option either repair or provide a new unit. The repaired or exchanged unit is under warranty for the remainder of the original product's warranty. Proof of purchase in the form of a bill of sale or receipted invoice which is evidence that the product is within the warranty period must be provided to obtain warranty service.

What the warranty does not cover:

- Any defects due to incorrect installation.
- Defects caused by exceeding the module's operating limits (e.g. over-voltage).
- Damage from misuse or neglect.
- Modules that have been modified or incorporated into other products.
- Acts of nature, such as but not limited to lightning damage.

Limitation of warranty:

- THE WARRANTY STATED ABOVE IS THE ONLY WARRANTY APPLICABLE TO THIS PRODUCT.
- ANY DAMAGE CAUSED TO A CAR BY INCORRECT INSTALLMENT IS NOT A WARRANTABLE CLAIM.
- WELTE ENGINEERING SHALL NOT BE LIABLE FOR INCIDENTAL OR CONSEQUENTIAL DAMAGES RESULTING FROM THE USE OF THIS PRODUCT.

4 Definitions of Terms

These abbreviations will be used in the following description:

ECU – Electronic Control Unit
OBD – On-Board Diagnostics
DTC – Diagnostic Trouble Code
SAE – Society of Automotive Engineers

5 Introduction

The **X-Gauge** is a sophisticated electronic module with a 128x64-pixel graphic display that replaces the original module inside the cockpit clock of a smart[®] fortwo (city-coupé) perfectly. It can not only tell time, but also date, battery voltage, inside temperature and a number of engine parameters in real-time. These parameters are retrieved from the car's engine control unit (ECU) through the on-board diagnostics (OBD) interface connector. The module can also display and clear engine trouble codes that the ECU might have stored.

Note that the **X-Gauge** will only work in the following cars:

- smart[®] fortwo, 2001 to 2006 with gasoline/petrol engine.
- smart[®] fortwo cdi, 2004 to 2006 with diesel engine.
- smart[®] roadster, all models.

These model limitations are due to the fact that the diagnostic interface in earlier models does not deliver the generic engine parameters that the **X-Gauge** requests from the ECU, while models after 2006 have a CAN based diagnostic interface implemented that the **X-Gauge** is not compatible with.

An **X-Gauge** made for the gasoline/petrol engine (fortwo or roadster) will not work in a fortwo cdi and vice-versa.

At present, the **X-Gauge** is deliverable in kit form only which means that your smart[®] must be equipped with the original cockpit clock.

Latest versions of this User Manual and the accompanying Installation Guide are available for downloading from our website.

6 Features and Specifications

6.1 Non-ECU Parameters

These parameters are displayed by the **X-Gauge** independently of the ECU. This means that if a display mode is set up for displaying only non-ECU parameters, no communications will take place between the **X-Gauge** and the ECU over the car's OBD interface. The top right pixel of the display is always used as an indicator for communication activities between **X-Gauge** and ECU. The pixel will be flashing whenever parameters are retrieved from the ECU. It will stay dark when no data is being exchanged.

<i>Parameter</i>	<i>Range</i>	<i>Remarks</i>
Time	-	User selectable to be either shown as a 12h or 24h clock. Accuracy†: ±10 ppm (±26 seconds/month)
Date	-	With automatic leap year correction.
Battery Voltage	8.0 .. 16.0 V	Accuracy†: ± 0.5 %
Inside Temperature	-20.0 .. 60.0 °C -4.0 .. 140 °F	Inside temperature as measured by a sensor located on the X-Gauge module. Accuracy†: ± 1 °C ± 3 %

†Not production tested.

Because the sensor for measuring the car's *Inside Temperature* is located within the **X-Gauge**'s housing, the displayed temperature might not always reflect the actual cabin temperature (e.g. when dash is exposed to direct sunlight).

6.2 ECU Parameters

Parameters in this category are retrieved from the ECU over the car's OBD interface in a request-reply fashion. A request-reply cycle takes approximately 180 ms per parameter. If, for instance, a display mode is set up with 4 ECU parameters, they will be repeatedly retrieved about every 720 ms, if 7 ECU parameters are assigned to a display mode they will be retrieved about every 1.3 seconds. Note that these parameters are displayed by the **X-Gauge** as delivered by the ECU without any post processing, such as averaging, and that the accuracy of these parameters is solely determined by the ECU and its connected sensors.

<i>Parameter († not cdi)</i>	<i>Range</i>	<i>Remarks</i>
# of Trouble Codes	-	Shows the total number of confirmed diagnostic trouble codes (DTC) stored by the ECU.
Fuel System †	Closed-failed Open-failed Open Closed Open-cold	Operation status of the fuel delivery control system.
Engine Load	0 .. 100 %	Percentage of peak available torque.
Coolant Temp.	-40 .. 215 °C -40 .. 419 °F	Engine coolant temperature derived from engine coolant temperature sensor.
Short Term Fuel Trim †	-100.0 .. +99.2 %	Correction being used by the closed loop fuel algorithm. If fuel system is open loop, 0% correction should be reported.
Long Term Fuel Trim †	-100.0 .. +99.2 %	Correction being used by the fuel control system in both open and closed loop modes of operation.
Intake Absolute Pressure	0.00 .. 2.55 bar 0.0 .. 36.9 psi	Absolute intake pressure derived from the manifold absolute pressure (MAP) sensor. Note: Relative pressure (Boost or Vacuum) = absolute pressure – ambient pressure. Ambient pressure is nominally ~1 bar (14.5 psi) at sea level.
Engine RPM	0 .. 16384 rpm	Engine revolutions per minute.
Vehicle Speed	0 .. 255 km/h 0 .. 158 mph	Vehicle road speed (a correction factor can be specified in order to compensate for error and/or different wheel sizes).
Ignition Timing Advance †	-64.0 .. 63.5°	Ignition timing advance for #1 cylinder (not including mechanical advance).
Intake Air Temp.	-40 .. 215 °C -40 .. 419 °F	Intake manifold air temperature.
Air Flow Rate †	0.0 .. 655.4 g/s 0.00 .. 86.70 lb/min	Airflow rate measured by the mass airflow sensor.
Absolute Throttle Position †	0 .. 100 %	Absolute throttle position. Usually above 0% at idle.
Secondary Air Status †	Off Upstream (Ups) Downstream (Dns)	Status of secondary source of air into the exhaust in order to burn remaining fuel before entering the catalytic converter.
Oxygen Sensor 1 Voltage †	0.000 .. 1.275 V	Voltage from oxygen sensor located ahead of catalytic converter. Higher values reflect a more rich mixture, lower values reflect a more lean mixture
Oxygen Sensor 2 Voltage †	0.000 .. 1.275 V	Voltage from oxygen sensor located behind catalytic converter.

ABS Front L †	0 .. 1500 pps	Pulse rate from ABS sensor of left front wheel.
ABS Front R †	0 .. 1500 pps	Pulse rate from ABS sensor of right front wheel.
ABS Rear L †	0 .. 1500 pps	Pulse rate from ABS sensor of left rear wheel.
ABS Rear R †	0 .. 1500 pps	Pulse rate from ABS sensor of right rear wheel.
Gear Position †	R, N, 1, 2, 3, 4, 5, 6	Selected gear position in manual and auto mode.
Gearbox Temp. †	-40 .. 215 °C -40 .. 419 °F	Gearbox temperature.

Note that Welte Engineering is not in a position to advise you if some particular ECU parameter of your smart[®] car is behaving in a correct manner or not. Please, do not contact us with any questions in this regard. If you are suspecting that your engine is malfunctioning bring your car to a smart[®] dealership.

6.3 Calculated Parameters

Parameters in this category are derived from one or more of the engine's ECU parameters.

<i>Parameter</i>	<i>Range</i>	<i>Remarks</i>
Mileage	0.0 .. 200 l/100 km 0.0 .. 999 mpg	Current fuel consumption.
Ø-Mileage	0.0 .. 200 l/100 km 0.0 .. 999 mpg	Average fuel consumption.
Maximum Speed	0 .. 255 km/h 0 .. 158 mph	Tracking of maximum vehicle road speed.
Acceleration	0.0 .. 100.0 s	Acceleration time measured between arbitrary start and end speed settings, based on vehicle speed reported by ECU. Error: 0 .. 400 ms
Maximum Acceleration	0.0 .. 100.0 s	Tracking of minimum acceleration time.
Turbo Cool Down Time	240 .. 0 s	Count down timer that starts whenever vehicle speed returns to 0 km/h or 0 mpg.

For gasoline engines, current and average mileage (fuel consumption) is estimated from ECU parameters *Air Flow Rate*, *Long Term Fuel Trim* and *Vehicle Speed*. For diesel engines, it is estimated from ECU parameters *Engine Load* and *Vehicle Speed*. The selection of parameters *Mileage* (current) and *Ø-Mileage* (average) will implicitly assign the needed ECU parameters to the selected display mode. Parameter *Ø-Mileage* can be reset via the user menu. Menu selections allow defining measurement units (l/100km or mpg) and gallon type (US or UK) to use for measurements in mpg. Mileage parameters are displayed with one decimal digit resolution for values below 100 l/100km or 100 mpg. Values equal or above this threshold are displayed without a decimal digit. Note that mileage can only be evaluated while the car is in motion (speed above 0). The display of *Mileage* will show a dash instead of a numeric value whenever the car is stopped. Accuracy of mileage evaluation will degrade if the car is driven in lots of stop and go traffic because fuel consumed during idle time can not be taken into account. Note that average mileage gets only updated if at least one of the two parameters *Mileage* or *Ø-Mileage* is assigned to the active display mode!

Maximum vehicle speed is tracked based on ECU parameter *Vehicle Speed* and can be reset via the user menu. ECU parameter *Vehicle Speed* will be implicitly assigned to a display mode if pa-

parameter *Maximum Speed* gets selected, so it does not have to be selected explicitly. If at least one of the parameters that depend on vehicle speed (*Vehicle Speed*, *Mileage*, *Ø-Mileage*, *Acceleration* or *Maximum Acceleration*) is assigned to a display mode, then parameter *Maximum Speed* will be updated even without it being explicitly assigned to the display mode. Maximum vehicle speed can be reset via menu selection.

Acceleration measurement is based on time and ECU parameter *Vehicle Speed*. Be aware that the accuracy of such measurements is limited by the request-reply cycle time for retrieving ECU parameters and the display update rate. In order to keep measurement error minimal (fastest request-reply cycle time) make sure that *Vehicle Speed* is the only ECU parameter that is assigned to the active display mode. Note that selection of parameter *Acceleration* will implicitly assign ECU parameter *Vehicle Speed* to a display mode, so it does not necessarily have to be selected explicitly. Start and end speed settings for these measurements are entered via menu selection as is explained later on.

Parameter *Maximum Acceleration* keeps track of the minimal achieved acceleration time. It can be reset via the user menu.

The turbo cool down timer is intended as a reminder that a hot engine should be kept running for some time before turning it off. When an engine runs at maximum power/high torque, the turbo charger is operating at very high temperatures and speeds. Hot shut down can cause reduced service life which is avoidable by a minute or two of idling. The turbo cool down timer of the **X-Gauge** starts counting seconds down from a user defined set value whenever vehicle speed returns to zero. This count down timer can be set from 0 .. 240 seconds and the user can select to display its time in either one of the three parameters *Vehicle Speed*, *Mileage* or *Ø-Mileage*. While the timer is running, the selected parameter changes from its regular display to the cool down time. Once the timer has elapsed or if speed gets above zero, the regular display of the parameter will return.

6.4 Display Modes

The user can choose from 5 distinct display modes for displaying the parameters described in the above tables.

<i>Display Mode</i>	<i>Remarks</i>
Time	Shows only non-ECU parameters <i>Date</i> , <i>Time</i> , <i>Battery Voltage</i> and <i>Inside Temperature</i> . No communications with the ECU are taking place.
Main	Up to 7 parameters can be displayed concurrently. Assignment of parameters to 7 possible display locations is freely selectable.
Text	Shows descriptions and corresponding values of up to 4 parameters. Assignment of parameters to display lines is freely selectable.
Graphic	Values of up to 2 parameters are plotted in x-y graphs that are scrolling from right to left.
Trouble Codes	Confirmed and pending diagnostic trouble codes (DTCs) are repeatedly retrieved from the ECU.

6.5 Diagnostic Trouble Codes

The **X-Gauge** is capable of retrieving confirmed as well as pending diagnostic trouble codes (DTCs) from the ECU. One or more confirmed trouble codes will most likely be recorded by the ECU if the check-engine symbol in the lower right corner of your instrument panel lights up unexpectedly while the engine is running. Remember that it is normal for this symbol to light up when the ignition gets turned on and to go out about 10 seconds after the engine got started. Trouble codes can be retrieved and displayed within a dedicated display mode and they can be cleared from the ECU via a special menu selection. The **X-Gauge** displays the actual trouble codes only, without interpreting them, so it won't tell the actual cause for triggering a particular code. While some codes are standardized according to SAE-J2012, others are manufacturer specific. You can also search the Internet for more information. There are numerous sites in the worldwide web that carry lists for trouble code interpretation. You can try <http://www.troublecodes.net/OBD2/> or <http://www.obdii.com/dtcanatomy.html>.

6.6 Languages

The language of parameter descriptions and menu selections can be chosen to be:

- English
 - German
 - French
 - Italian
 - Spanish.
-

6.7 Units

Metric or English units can be selected for displaying numeric parameters:

- °C or °F for temperature
- *bar* or *psi* for pressure
- *g/s* or *lb/min* for air flow
- *km/h* or *mph* for speed
- *l/100km* or *mpg* for mileage

Note that metric and English units can be mixed. While, for instance, temperature is chosen to be displayed in °C, pressure can be selected to be shown in *psi*.

6.8 Display Intensity

Intensity of the **X-Gauge** display can be adjusted in 10 steps for day as well as for night driving conditions. Depending whether the driving lights of your car are switched on or off, the display intensity can be chosen to be dimmer at night and brighter during the day.

6.9 Module Specifications





Supply Voltage Range	8 .. 16 V
Operating Current (Ignition On)	~12 mA at 12 V supply (depending on display content)
Idle Current (Ignition Off)	~0.8 mA at 12 V supply
Operating Temperature Range	-30 .. +70 °C
Display Technology	Organic LED
Display Resolution	128 Columns x 64 Rows (4-bit grayscale)
Display Color	Yellow
Display Active Area	36.5 mm width, 18.2 mm height
Display Luminance	100 cd/m ² typical
Display Contrast Ratio	100:1 minimum
Display Viewing Angle	160°
Display Lifetime	10'000 hours at 25 °C (half luminance)
Button Operating Life	1'000'000 cycles min.

7 Operation

The **X-Gauge** responds to the following events

- Ignition on/off
- Driving lights switch on/off
- Left Button
- Right Button

Left and right button designations are defined as viewed from the driver's seat. Since user operation is limited to two buttons, a distinction is made whether a button is pushed and released within 2 seconds (short) or pushed down for more than 2 seconds (long). Button activity is abbreviated throughout the following descriptions as shown in the box below.

	LEFT button pushed SHORT
	LEFT button pushed LONG
	RIGHT button pushed SHORT
	RIGHT button pushed LONG

7.1 Ignition Off





The display of the **X-Gauge** stays dark while ignition is off. Current consumption in this state is minimized and even less than the one from the original cockpit clock so battery drain is negligible. The display below is shown while ignition is off under the following conditions:

- While the driving lights are switched on and for another 30 seconds after the lights have been switched off.
- After pushing either LBS or RBS for the duration of 30 seconds.



- top line: *Date*
- center line: *Time (seconds in small letters)*
- bottom line right: *Inside Temperature*

Functionality of buttons while display is on:

	Turn display off immediately (if driving lights are switched off).
	not used.
	Turn display off immediately (if driving lights are switched off).
	Enter <i>Main Menu</i> .

Note that this display will also be shown for 30 seconds after ignition has been turned off.

7.2 Ignition On

When ignition gets turned on, the **X-Gauge** will show one of 5 possible display modes which is either the same one that was active when ignition got turned off or the one that got selected in submenu *Select Display Mode* while ignition was off.

Changing from one display mode to another can be done by pushing LBL which switches them sequentially (Time - Main - Text - Graphic - Trouble Codes - Time - ...) or directly through submenu *Select Display Mode*.



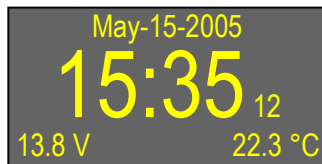

7.2.1 Display Mode: Time

This display mode shows all non-ECU parameters which means that no communications whatsoever with the car's ECU are taking place.



- top line: *Date*
- center line: *Time (seconds in small letters)*
- bottom line left: *Battery Voltage*
- bottom line right: *Inside Temperature*

Functionality of buttons while in this display mode:

	not used.
	Change display mode to <i>Main</i> .
	not used.
	Enter <i>Main Menu</i> .





7.2.2 Display Mode: Main

Up to 7 parameters can be displayed concurrently in this display mode. Which parameter is displayed at which display location is freely selectable. Top and bottom lines can have up to 3 parameters assigned while the center line can show one parameter in large letters. The idea here is, of course, that the parameter which matters most to the driver is placed into the display center while other, less important ones, are placed into the top and bottom lines. Parameter assignment as shown below is just an example.



- top line left: *Fuel System*
- top line center: *Average Fuel Consumption (l/100km)*
- top line right: *Coolant Temperature*
- center line: *Intake Absolute Pressure*
- bottom line left: *Battery Voltage*
- bottom line center: *Time (hours and minutes)*
- bottom line right: *Inside Temperature*

Functionality of buttons while in this display mode:

	Change parameter assignment at selected display location.
	Change display mode to <i>Text</i> .
	Select display location for changing parameter assignment.
	Enter <i>Main Menu</i> .

Having that many parameters shown concurrently does not leave any room for also showing the parameter descriptions, so the user must remember his assignments. In the display example shown above he must recall, for instance, that the temperature value as shown at the top line right location displays coolant temperature and not intake air temperature.

Changing Parameter Assignment:

Hitting RBS repeatedly will move the display location for changing parameter assignment sequentially from top line left to bottom line right. A highlighted description of the assigned parameter is shown at the currently selected display location. The picture sequence below shows how the display may look like if RBS is hit repeatedly for the display example shown above.

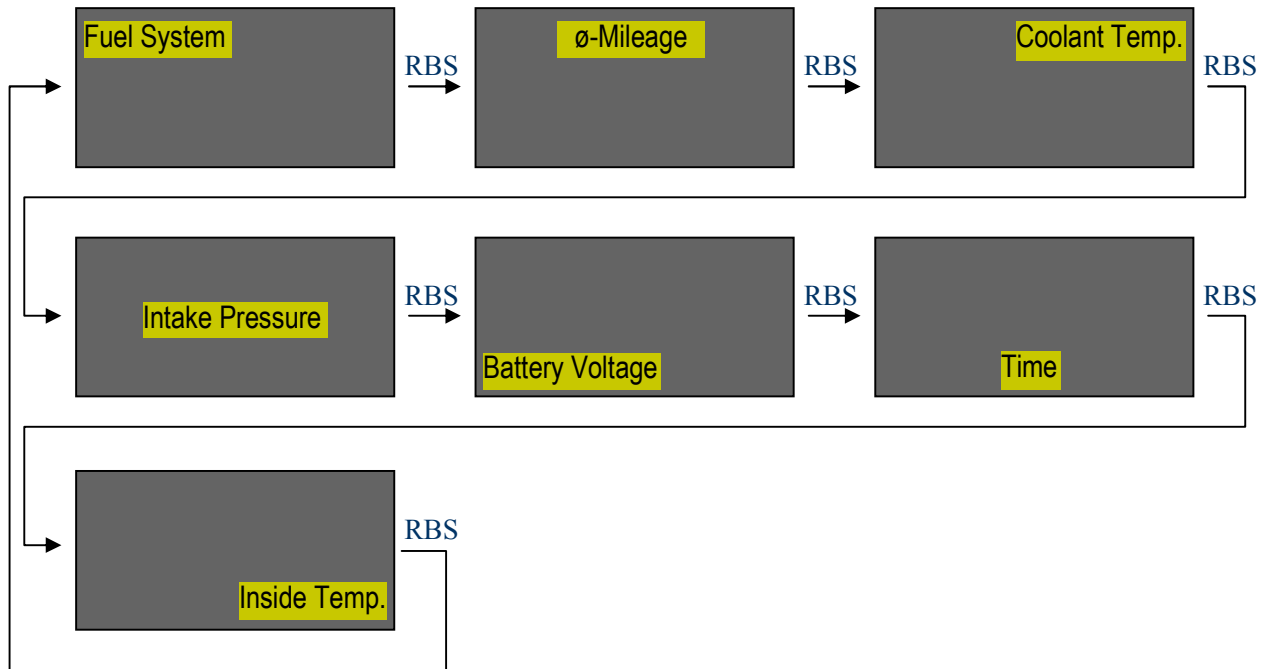

Once a desired display location is reached, hitting LBS repeatedly will cycle through the available parameters according to the tables shown in chapters 6.1, 6.2 and 6.3. If the desired parameter is reached, RBS can be pushed again for moving to the next display location. If neither RBS nor LBS are pushed within 4 seconds, parameter assignment gets finalized and the display will return to showing the values of the assigned parameters.

Notes:

- Parameter assignment is saved even if display mode is changed or ignition gets turned off.
- Display location that was selected last by RBS is saved also. For instance, if display location is set to be the center line, LBS can be pushed at any time for changing the parameter displayed in the center line.
- Initial RBS will highlight the current display location without changing it. Subsequent RBS will advance display location sequentially.
- When cycling through the parameters with LBS, an additional parameter described by 3 dashes (---) is put at the end of the list. It serves as an indication that the bottom of the parameter list has been reached. It can also be selected if no parameter at all should be assigned to a given display location.
- Only numeric parameters can be assigned to the center line.
- Some parameter combinations won't fit properly next to each other on the same display line because they take up too much space. For example, *Vehicle Speed* and *Engine RPM* can be assigned beside each other but it does not make much sense to do so since they would overlap.
- Mileage parameters that are selected to be displayed in l/100km will only show their full unit string 'l/100km' when displayed in the center line. The unit string will be abbreviated to 'l' (liters) when a mileage parameter is assigned to the top or bottom lines in order to prevent overlapping with neighboring parameters.





7.2.3 Display Mode: Text

This display mode is limited to showing 4 parameters concurrently, but it does not only show the parameter values but also their descriptions. Parameter assignment as shown below is just an example.

Intake Pressure	1.53 bar
Engine Load	62 %
Coolant Temp.	86 °C
Fuel System	Closed

- line 1: *Intake Absolute Pressure*
- line 2: *Engine Load*
- line 3: *Coolant Temperature*
- line 4: *Fuel System*

Functionality of buttons while in this display mode:

	Change parameter assignment at selected display line.
	Change display mode to <i>Graphic</i> .
	Select display line for changing parameter assignment.
	Enter <i>Main Menu</i> .

Changing Parameter Assignment:

Hitting RBS repeatedly will move the display line for changing parameter assignment sequentially from line 1 to line 4 with the parameter description of the currently selected line highlighted. The picture sequence below shows how the display may look like if RBS is hit repeatedly for the display example shown above.

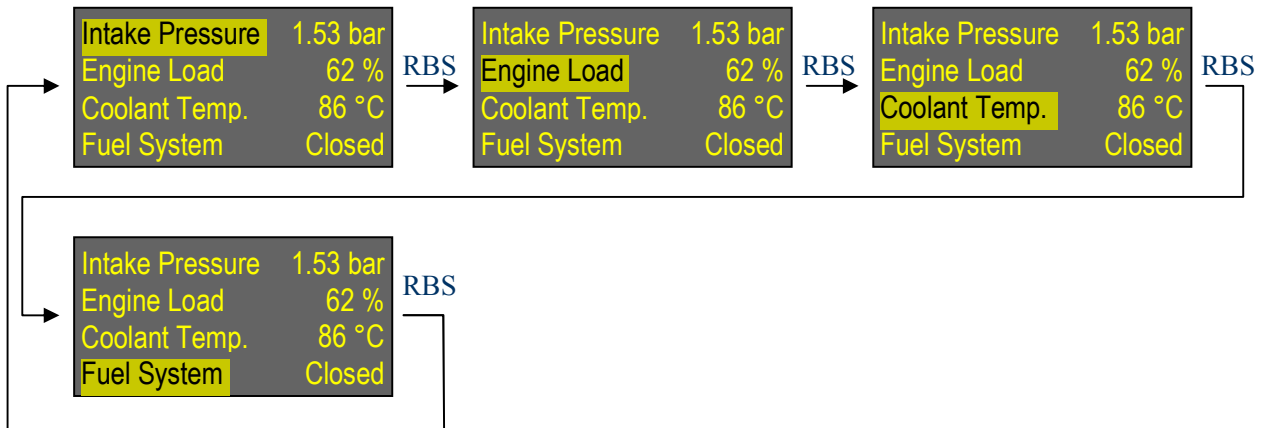

Once a desired display line is reached, hitting LBS repeatedly will cycle through the available parameters according to the tables shown in chapters 6.1, 6.2 and 6.3. If the desired parameter is reached, RBS can be pushed again for moving to the next display line. If neither RBS nor LBS are pushed within 4 seconds, parameter assignment gets finalized and highlighting of the currently selected line is turned off.

Notes:

- Parameter assignment is saved even if display mode is changed or ignition gets turned off.
- Display line that was selected last by RBS is saved also. For instance, if display line 2 was selected last, LBS can be pushed at any time for changing the parameter displayed at line 2.
- Initial RBS will highlight the current display line without changing it. Subsequent RBS will advance display line sequentially.
- When cycling through the parameters with LBS, an additional parameter described by 3 dashes (---) is put at the end of the list. It serves as an indication that the bottom of the parameter list has been reached. It can also be selected if no parameter at all should be assigned to a given display line.
- Mileage parameters that are selected to be displayed in l/100km will be shown with an abbreviated unit string 'l' (liters) in order to save space.

7.2.4 Display Mode: Graphic



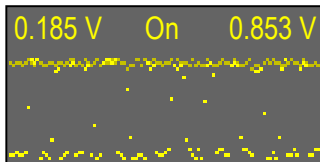

This display mode shows the history of up to 2 numeric parameters plotted in x-y graphs. Points are drawn from left to right until the right hand side of the display is reached. The graphs then start scrolling from right to left as new points are drawn. Current values of the parameters being plotted are shown in the top line of the display with the left and right values belonging to graph 1 and 2 respectively. Graph 2 is plotted with less intensity than graph 1 so that they are more easily distinguishable. An ON/Off selector is located in the center of the top line between the parameter values. Graphing can be enabled or disabled by setting this selector accordingly.

Parameter assignment as shown below is just an example on how the display might look like when plotting voltages of the two oxygen sensors (while fuel system is in closed mode).



- graph 1: *Oxygen Sensor 1 Voltage (ahead of catalyst)*
- graph 2: *Oxygen Sensor 2 Voltage (behind catalyst)*

Functionality of buttons while in this display mode:

	Change parameter assignment of selected graph or change On/Off selector.
	Change display mode to <i>Trouble Codes</i> .
	Select graph for changing parameter assignment or select On/Off selector.
	Enter <i>Main Menu</i> .

Changing Parameter Assignment:

Hitting RBS repeatedly will move the display location for changing parameter assignment or On/Off selector with the currently selected location being highlighted. The picture sequence below shows how the display may look like if RBS is hit repeatedly for the display example shown above.

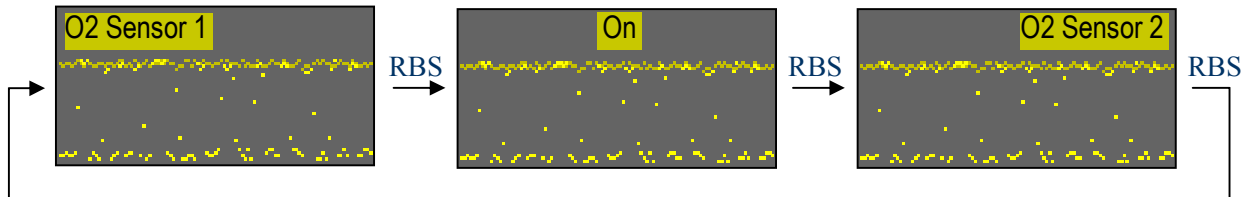

Once a desired display location is reached, hitting LBS repeatedly will cycle through the available parameters according to the tables shown in chapters 6.1, 6.2 and 6.3. If the desired parameter is reached, RBS can be pushed again for moving to the next display location. If neither RBS nor LBS are pushed within 4 seconds, parameter assignment gets finalized and highlighting of the currently selected location is turned off.

Notes:

- Only numeric parameters suitable for graphical display can be selected with LBS.
- Parameter assignment is saved even if display mode is changed or ignition gets turned off.
- Display location that was selected last by RBS is saved also. For instance, if On/Off selector was selected last, LBS can be pushed at any time for enabling/disabling updating of graphs.
- Initial RBS will highlight the current display location without changing it. Subsequent RBS will advance display location sequentially.
- Graphs are kept in memory when On/Off selector is turned to Off, even if display mode is changed or ignition gets turned off, so that graphs can be redisplayed at a later time.
- On/Off selector is always shown in the English language because other languages would take up too much display space.
- When cycling through the parameters with LBS, an additional parameter described by 3 dashes (---) is put at the end of the list. It serves as an indication that the bottom of the parameter list has been reached. It can also be selected if a graph should not be drawn.
- Mileage parameters that are selected to be displayed in l/100km will be shown with an abbreviated unit string 'l' (liters) in order to save space.
- If a graph is assigned to a mileage parameter display scrolling will be interrupted whenever the car is stopped since mileage is not defined when speed is equal to zero.
- Y-axis scaling is done according to the expected range of parameter values for the smart[®] engine as is shown in the following table.

<i>Parameter for Graphic Display</i>	<i>Range y-min .. y-max</i>
Battery Voltage	8 .. 16 V
Engine Load	0 .. 100 %
Coolant Temp.	-10 .. 120 °C (14 .. 248 °F)
Short Term Fuel Trim	-70 .. 70 %
Long Term Fuel Trim	-70 .. 70 %
Intake Absolute Pressure	0.00 .. 2.55 bar (0.0 .. 36.9 psi)
Engine RPM	0 .. 7000 rpm
Vehicle Speed	0 .. 150 km/h (0 .. 93 mph)
Ignition Timing Advance	-40 .. 10 °
Intake Air Temp.	-10 .. 60 °C (14 .. 140 °F)
Air Flow Rate	0 .. 60 g/s (0.0 .. 7.9 lb/min)
Absolute Throttle Position	0 .. 100 %
Oxygen Sensor 1 Voltage	0.000 .. 1.275 V
Oxygen Sensor 2 Voltage	0.000 .. 1.275 V
Mileage	0.0 .. 10.0 l/100km (0.0 .. 120 mpg)
Ø-Mileage	0.0 .. 10.0 l/100km (0.0 .. 120 mpg)
ABS Front/Rear L/R	0 .. 1000 pps
Gearbox Temp.	-10 .. 60 °C (14 .. 140 °F)

7.2.5 Display Mode: Trouble Codes





This display mode will retrieve diagnostic trouble codes from the ECU if any are stored. Stored trouble codes are either confirmed codes or pending codes. Confirmed codes indicate serious problems that the ECU has detected over 2 driving cycles (driving cycle: start engine – drive – stop engine). Confirmed codes will also turn on the check-engine light in the lower right corner of your instrument panel. Pending codes indicate problems that the ECU has detected during the current or last driving cycle and are not considered serious yet, so pending codes will not turn on the check-engine light. A pending code will turn into a confirmed one if it has been detected over more than 1 driving cycle. The **X-Gauge** continuously displays confirmed and pending codes alternatively.



- top line: *Total number of stored confirmed or pending trouble codes*
- center line: *Trouble Code retrieved (sequence number in small letters)*
- bottom line left: *Origin of trouble code*
- bottom line right: *Standardized or manufacturer specific code*



Functionality of buttons while in this display mode:

	not used.
	Change display mode to <i>Time</i> .
	not used.
	Enter <i>Main Menu</i> .

Notes:

- Center line will show a dash if no trouble codes are stored.
- Trouble codes are shown repeatedly at a rate of one code per 5 seconds. A small number displayed to the right of the trouble code indicates the sequence number of the currently displayed code. For instance, if the ECU has stored 2 trouble codes then the two codes will be displayed one after another with corresponding sequence numbers 1 and 2.
- Origin of trouble code (bottom line left) can either be: Powertrain, Body, Chassis, Network.
- A code can either be a standardized one according to SAE-J2012 or it can be specific to the manufacturer of the car (when bottom line right shows *Manufacturer Specific*).
- More information regarding SAE-J2012 codes can be found on the Internet, for instance under <http://www.troublecodes.net/OBD2/> or <http://www.obdii.com/dtcanatomy.html>.
- Do not contact Welte Engineering for interpretation of trouble codes that your car's ECU has recorded. Since we won't be able to help with such questions, you should have your car inspected at a smart® dealership.

8 Menu

Numerous features of the **X-Gauge** are determined by settings through the user menu. The chart below shows how this menu is organized.

	Submenu	Selections	Possible Settings
Main Menu	Mileage Settings	Correction	-50 .. 100 %
		Gallon ¹⁾	US - UK
	Speed Correction	Correction	-20 .. 20 %
	Acceleration Settings	From	0 .. 195 km/h (0 .. 120 mph)
		Until	5 .. 200 km/h (5 .. 125 mph)
	Turbo Settings	Ambient Pressure	0.00 .. 1.20 bar (0.0 .. 18.0 psi)
		Cool down Time	0 .. 240 s
		Shown at ²⁾	Vehicle Speed - Mileage - Ø-Mileage
	Select Display Mode	Display	Time - Main - Text - Graphic - Trouble Codes
		Type	Normal - Inverse
		Horizontal Flip	No - Yes
		Vertical Flip	No - Yes
	Set Time	Time Format	24h - 12h
		Hour	0 .. 23
		Minute	0 .. 59
	Set Date	Year	2005 .. 2040
		Month	Jan .. Dec
		Day	1 .. 31
	Select Units	Temperature	°C - °F
		Pressure	bar - psi
		Air Flow	g/s - lb/min
		Speed	km/h - mph
		Mileage	l/100km - mpg
	Select Language	Language	English - Deutsch - Français - Italiano - Español
	Select Greeting	Greeting	Standard - Short - None
	Set Display Intensity	Intensity Day	1 .. 10
		Intensity Night	1 .. 10
	View System Info		none (for information only)
	Clear Trouble Codes ³⁾	Clear codes ?	No - Yes
	Factory Reset	Reset ?	No - Yes

¹⁾ Only available if Mileage units are set to mpg.

²⁾ Only available if Cool Down Time is greater than zero.



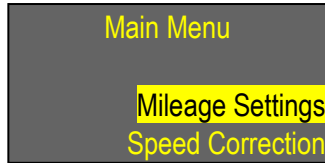

³⁾ Only available if ignition is turned on.

8.1 Main Menu

Pushing RBL in all display modes will enter the main menu display with two submenus shown in the bottom lines of the display.



Functionality of buttons while in main menu:

	Scroll to next submenu.
	Scroll through submenus automatically at a rate of 3 per second.
	Enter submenu.
	Exit Main Menu.

Notes:

- Main menu is exit if neither RBS nor LBS are pushed within 10 seconds (timeout).
- When scrolling through submenus with LBS, an indicator of 3 dashes (---) is put after submenu *Factory Reset* and before submenu *Select Display Mode*. It's simply there as a sign that the bottom of the submenu list has been reached.
- Having only 2 buttons available, submenus can be scrolled up but not down.

8.1.1 Submenu: Mileage Settings

Settings relevant for evaluation of current and average mileage are selected within this submenu.



Functionality of buttons while in submenu:

	Increment correction factor within -50 .. 100% in steps of 2%. Change setting for gallon (US - UK).
	Increment correction factor automatically 3 times per second.
	Accept setting and move to next selection. Exit submenu after last selection AND reset parameter \emptyset -Mileage.
	Exit submenu <u>without</u> accepting any new settings and without resetting parameter \emptyset -Mileage.

Notes:

- Submenu is exit if neither RBS nor LBS are pushed within 10 seconds (timeout) without accepting any new settings and without resetting parameter \emptyset -Mileage.
- Selection for Gallon will NOT appear if mileage units are set to l/100km.
- Having only 2 buttons available, correction factor can be incremented but not decremented. It will wrap around from 100% to -50%.
- Average mileage (\emptyset -Mileage) is reset when this submenu is exit after last selection via RBS (leaving submenu via timeout or RBL will not reset average mileage!). If \emptyset -Mileage is to be reset without changing any submenu settings, enter this submenu menu and hit RBS repeatedly until submenu is exit.
- Correction factor can be used for calibration of current and average mileage evaluations according to the following procedure:
 - Make sure that you have first verified (and possibly corrected) the accuracy of the *Vehicle Speed* parameter of the **X-Gauge**. For details, see the description of submenu *Speed Correction*.
 - Fill gas tank completely, reset the car's trip odometer and reset \emptyset -Mileage parameter of **X-Gauge**. Make sure that the gallon setting (US or UK) is set according to the gallons used by your country's fuel pumps.
 - At next fill-up write down trip odometer reading (km or miles), fuel (liters or gallons) that were needed to completely refill the gas tank and \emptyset -Mileage [l/100km or mpg) as shown by the **X-Gauge**.

- Adjust correction factor according to (factor must be rounded up or down to the nearest even percentage number):

for Metric units:

$$Correction_{[\%]} = 100 \times \left[\frac{100 \times Fuel_{[liters]}}{Odometer_{[km]} \times \emptyset - Mileag_{[1/100km]}} - 1 \right]$$

example: fuel required for fill-up:	31.5 liters
distance driven until fill-up:	595 km
X-Gauge \emptyset -Mileage shown at fill-up:	5.5 l/100km
→ set correction factor to:	- 4 % (rounded up from -3.74 %)

For English units:

$$Correction_{[\%]} = 100 \times \left[\frac{Odometer_{[miles]}}{Fuel_{[gallons]} \times \emptyset - Mileag_{[m\ pg]}} - 1 \right]$$



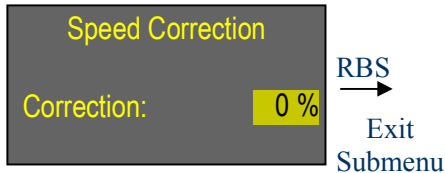

example: fuel required for fill-up:	8.65 gallons
distance driven until fill-up:	361 miles
X-Gauge \emptyset -Mileage shown at fill-up:	38.2 mpg
→ set correction factor to:	+ 10 % (rounded up from +9.25 %)

8.1.2 Submenu: Speed Correction

This submenu facilitates the specification of a correction factor that gets applied to the vehicle speed value reported by the ECU. This correction factor can be used for compensation of inherent measurement errors and/or for adjustment to non-standard wheel sizes. Calibration might be carried out with the help of a GPS unit. Parameter *Maximum Speed* is also reset through this submenu.



Functionality of buttons while in submenu:

	Increment correction factor within -20 .. 20% in steps of 1%.
	Increment correction factor automatically 3 times per second.
	Accept selected correction factor and exit submenu. Reset parameter <i>Maximum Speed</i> .
	Exit submenu <u>without</u> accepting any new correction factor and without resetting parameter <i>Maximum Speed</i> .

Notes:

- Submenu is exit if neither RBS nor LBS are pushed within 10 seconds (timeout) without accepting any new correction factor and without resetting parameter *Maximum Speed*.
- The specified correction factor will influence any speed derived parameters, e.g. *Mileage*, *Ø-Mileage*, *Maximum Speed*, and *Acceleration*.
- Having only 2 buttons available, correction factor can be incremented but not decremented. It will wrap around from 20% to -20%.
- Parameter *Maximum Speed* is reset whenever this submenu is exit after selection via RBS (leaving submenu via timeout or RBL will not reset *Maximum Speed* parameter!). If *Maximum Speed* is to be reset without changing the correction factor, just enter this submenu menu and hit RBS right away to exit.

8.1.3 Submenu: Acceleration Settings

Start and end speed settings for measuring the car's acceleration are selected within this submenu.

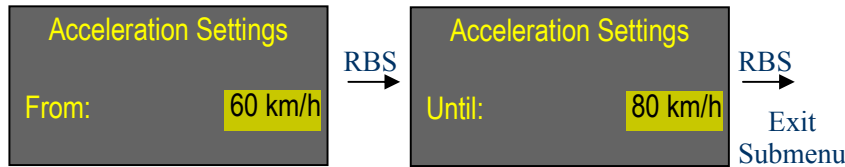

Functionality of buttons while in submenu:

	Increment start or end speed setting by 5 km/h (5 mph for speed units mph).
	Increment start or end speed setting by 5 km/h automatically 3 times per second.
	Accept setting and move to next selection. Exit submenu after last selection and reset parameter <i>Maximum Acceleration</i> .
	Exit submenu <u>without</u> accepting any new speed settings and without resetting parameter <i>Maximum Acceleration</i> .

Notes:

- Submenu is exit if neither RBS nor LBS are pushed within 10 seconds (timeout) without accepting any new speed settings and without resetting parameter *Maximum Acceleration*.
- Having only 2 buttons available, speed settings can be incremented but not decremented.
- Setting for start speed can be selected within 0 .. 195 km/h (0 .. 120 mph). Setting for end speed can be selected within 'start speed + 5 km/h' .. 200 km/h ('start speed + 5 mph' .. 125 mph).
- The value of parameter *Maximum Acceleration* will be reset if this submenu is exit via RBS. If *Maximum Acceleration* shall be reset without changing start and end speed settings simply push RBS twice after having entered this submenu.
- Be aware that the error of an acceleration measurement can be anywhere from 0 .. 0.4 seconds due to ECU request-reply time and display update rate. The maximum error of 0.4 seconds can be even larger if any other ECU parameter next to *Vehicle Speed* is assigned to the active display mode. Selection of parameter *Acceleration* will implicitly assign ECU parameter *Vehicle Speed*, so it does not necessarily have to be selected explicitly.

8.1.4 Submenu: Turbo Settings

Turbo related settings are defined within this submenu.

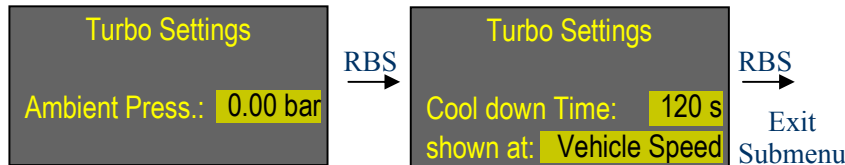

Functionality of buttons while in submenu:

	Increment ambient pressure by 0.05 bar (0.5 psi for pressure units psi), increment cool down time by 5 seconds or change 'shown at' parameter for displaying cool down time.
	Increment ambient pressure or cool down time automatically 3 times per second.
	Accept setting and move to next selection. Exit submenu after last selection.
	Exit submenu <u>without</u> accepting any new settings.

Notes:

- Submenu is exit if neither RBS nor LBS are pushed within 10 seconds (timeout) without accepting any new settings.
- Having only 2 buttons available, ambient pressure and cool down time settings can be incremented but not decremented. Ambient pressure will wrap around from 1.20 bar to 0.00 bar (18.0 psi to 0.0 psi) and cool down time will wrap around from 240 s to 0 s.
- 'Shown at' setting will only appear if cool down time is set above zero. It determines the parameter where cool down time will be shown when vehicle speed has reached zero. This setting can be either one of the three parameters *Vehicle Speed*, *Mileage* or *Ø-Mileage*.
- The display of cool down time is disabled if cool down time is set to zero.
- Setting for ambient pressure can be used for converting the absolute pressure value that is reported by the ECU into a relative pressure value that is interpreted as boost for positive values and vacuum for negative values according to:

$$\text{Relative pressure (boost [+] or vacuum [-])} = \text{Absolute pressure} - \text{Ambient pressure}$$

Ambient pressure is nominally 1.0 bar (14.5 psi) at sea level. However, it is very important to understand that ambient pressure is a fluctuating value. It is dependent on altitude, temperature and weather conditions in general. For a given altitude, it can change from day to day or even from hour to hour. For instance, if ambient pressure at sea level is 1.0 bar and temperature is a constant 15 degrees Celsius, ambient pressure will be down at 0.89 bar when an altitude of 1000 meters is reached. So, if one would set the **X-Gauge**'s ambient pressure value to 1.00 bar at sea level and the ECU would report an absolute pressure value of 0.95 bar at sea level as well as at 1000 meters, then the **X-Gauge** would always display a relative pressure of -0.05 bar. At 1000 meters, however, the correct relative pressure would be +0.06 bar since ambient pressure is 0.89 bar at this altitude. Assuming constant absolute pressure, vacuum has changed into boost by driving from sea level to an altitude of 1000 meters. But the **X-Gauge** can not display this difference correctly, because it has

no information about any changes in ambient pressure. Unfortunately, the smart[®] engine does not have an ambient pressure sensor.

If you decide to set ambient pressure in this submenu to a value other than zero, you must be aware that your displayed relative pressure will only be accurate as long as the actual ambient pressure is exactly the same as the one that has been set in this submenu!

- If ambient pressure in this submenu is set to 0.0 bar (0.0 psi) then parameter *Intake Pressure* will always display the absolute pressure without consideration of actual ambient pressure.

8.1.5 Submenu: Select Display Mode

As described previously, display modes can be changed from one mode to the next by pushing LBL while in a display mode. Alternatively, a certain display mode can be chosen directly through this submenu. Additionally, this submenu lets the user choose if the display is shown in normal or inverse type and if the display should be flipped horizontally and/or vertically.

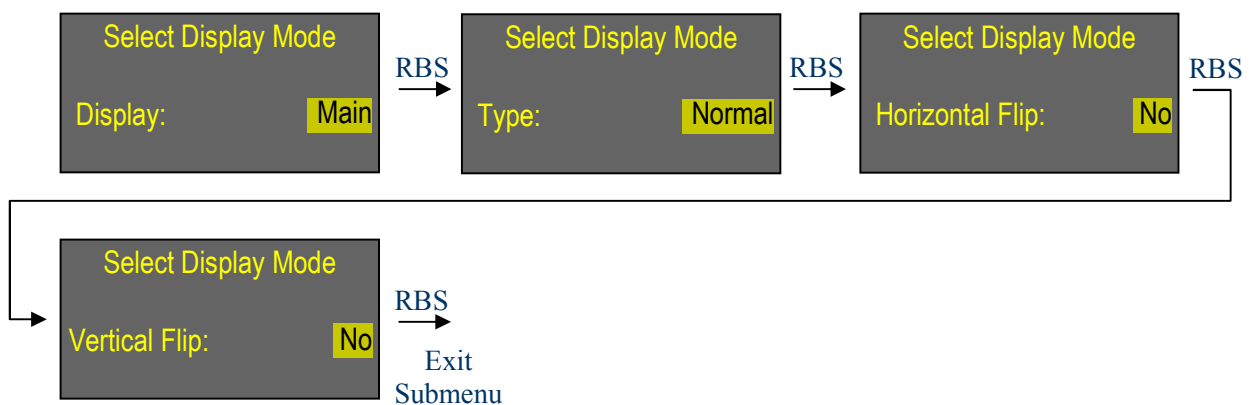

Functionality of buttons while in submenu:

	Advance to next display mode, select between normal and inverse type or change horizontal/vertical flip settings between Yes and No.
	Advance to next display setting automatically at a rate of 3 per second.
	Accept setting and move to next selection. Exit submenu after last selection.
	Exit submenu <u>without</u> accepting any new settings.

Notes:

- Submenu is exit if neither RBS nor LBS are pushed within 10 seconds (timeout) without accepting any new display mode settings.
- The type setting determines if the display is shown normally (white on black) or inversed (black on white).
- Horizontal and/or vertical flip settings are intended for non-standard installations of the **X-Gauge**. Enabling both settings with *Yes*, for instance, will rotate the display by 180 degrees. The two flip settings will not take effect immediately (this would get rather confusing) but will so after the submenu is exit with RBS.



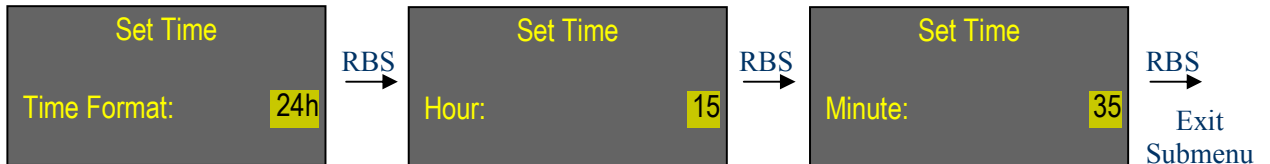

<i>Horizontal Flip</i>	<i>Vertical Flip</i>	<i>Display Orientation</i>
No	No	
No	Yes	
Yes	No	
Yes	Yes	

8.1.6 Submenu: Set Time

This submenu for setting actual time consists of 3 selections as show below.



Functionality of buttons while in submenu:

	Switch time format between 24h - 12h, or increment setting for hour or minute.
	Increment setting for hour or minute automatically 3 times per second.
	Accept setting and move to next selection. Exit submenu after last selection.
	Exit submenu <u>without</u> accepting any new time settings.

Notes:





- Submenu is exit if neither RBS nor LBS are pushed within 10 seconds (timeout) without accepting any new time settings.
- Having only 2 buttons available, hours and minutes can be incremented but not decremented.
- Time is updated with newly set hour and minute and with seconds cleared to 0 at the moment when submenu is exit (RBS pushed after having set minutes).

8.1.7 Submenu: Set Date

This submenu for setting actual date consists of 3 selections as show below.



Functionality of buttons while in submenu:

	Increment setting for year, month or day.
	Increment setting for year, month or day automatically 3 times per second.
	Accept setting and move to next selection. Exit submenu after last selection.
	Exit submenu <u>without</u> accepting any new date settings.

Notes:



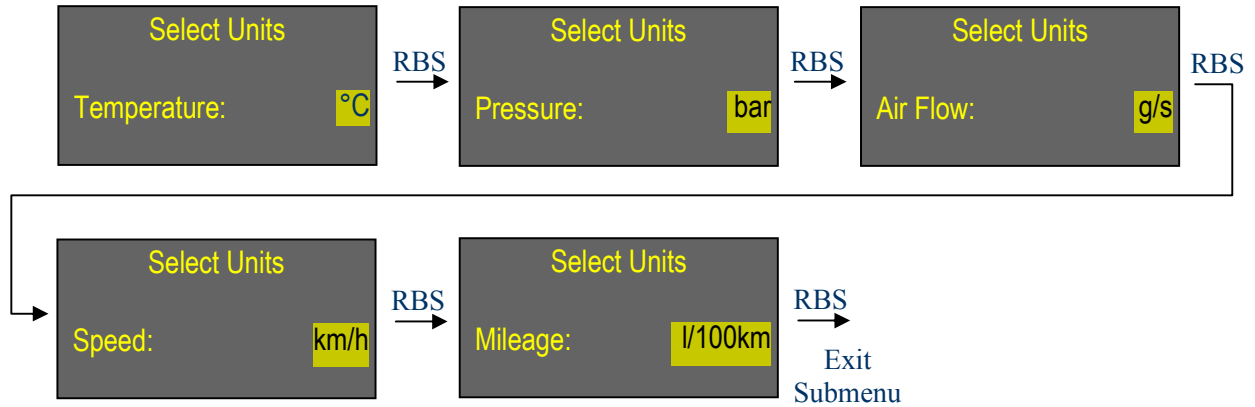

- Submenu is exit if neither RBS nor LBS are pushed within 10 seconds (timeout) without accepting any new date settings.
- Having only 2 buttons available, years, months and days can be incremented but not decremented. Maximum year setting is limited to 2040 after which it will wrap back to 2005.
- Date is updated with newly set year, month and day at the moment when submenu is exit (RBS pushed after having set day).

8.1.8 Submenu: Select Units

This submenu for selecting units consists of 5 selections as show below.



Functionality of buttons while in submenu:

	Change setting between °C - °F, bar - psi, g/s - lb/min, km/h - mph or l/100km - mpg.
	not used.
	Accept setting and move to next selection. Exit submenu after last selection.
	Exit submenu <u>without</u> accepting any new units settings.

Notes:



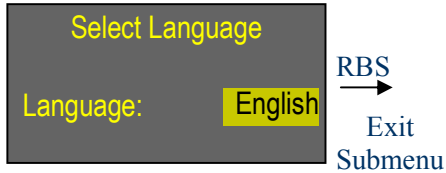

- Submenu is exit if neither RBS nor LBS are pushed within 10 seconds (timeout) without accepting any new units settings.

8.1.9 Submenu: Select Language

Language to use for parameter descriptions and menu text are selected with this submenu.



Functionality of buttons while in submenu:

	Change language (English - Deutsch - Français - Italiano - Español).
	Change setting between languages automatically 3 times per second.
	Accept selected language setting and exit submenu.
	Exit submenu <u>without</u> accepting any new language setting.

Notes:



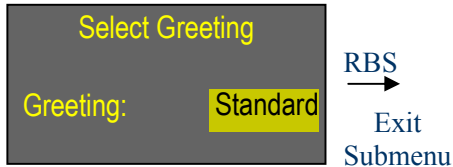

- Submenu is exit if neither RBS nor LBS are pushed within 10 seconds (timeout) without accepting any new language setting.

8.1.10 Submenu: Select Greeting

By default, the **X-Gauge** shows a greeting display sequence every time ignition gets turned on. This submenu allows changing the greeting sequence from its default setting (standard length) to a shorter sequence or no greeting at all.



Functionality of buttons while in submenu:

	Change greeting length (Standard - Short - None).
	Change between greeting lengths automatically 3 times per second.
	Accept selected greeting length and exit submenu.
	Exit submenu <u>without</u> accepting any new greeting setting.

Notes:





- Submenu is exit if neither RBS nor LBS are pushed within 10 seconds (timeout) without accepting any new greeting setting.

8.1.11 Submenu: Set Display Intensity

The display's intensity for day and night driving can be adjusted in this submenu from level 1 to 10. Day intensity is active while the driving lights of the car are turned off, night intensity when the lights are turned on.



Functionality of buttons while in submenu:

	Increment intensity setting for day or night.
	Increment intensity setting for day or night automatically 3 times per second.
	Accept setting and move to next selection. Exit submenu after last selection.
	Exit submenu <u>without</u> accepting any new intensity settings.

Notes:

- Submenu is exit if neither RBS nor LBS are pushed within 10 seconds (timeout) without accepting any new intensity settings.
- Having only 2 buttons available, intensity settings can be incremented but not decremented. They will wrap around from 10 to 1.

8.1.12 Submenu: View System Info



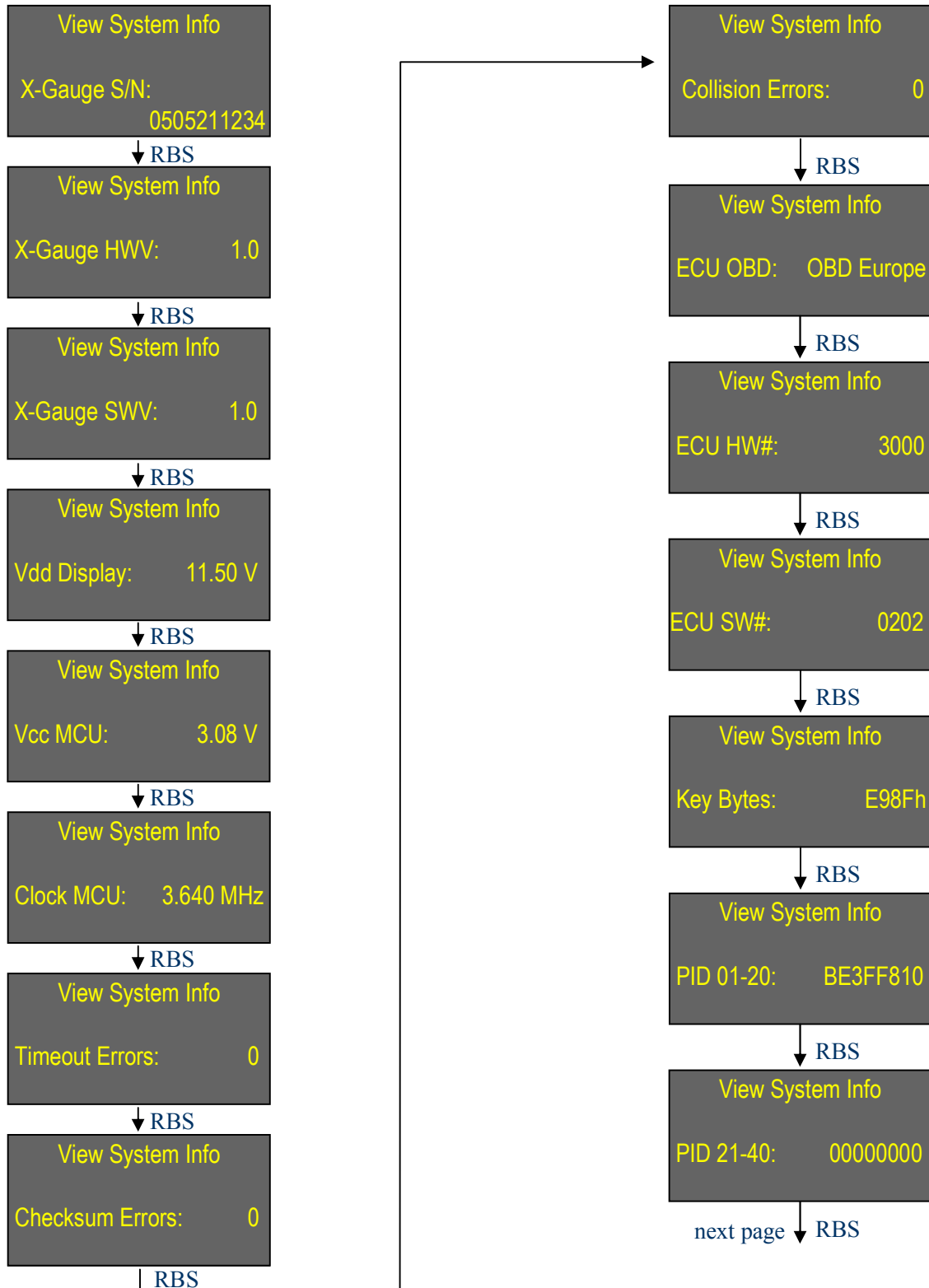

This submenu presents some status information of the *X-Gauge* system.

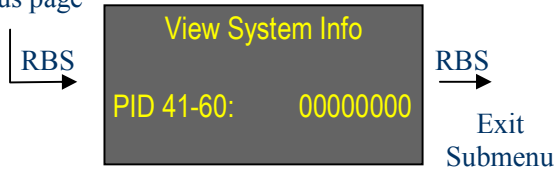

from
previous page



Functionality of buttons while in submenu:

	not used.
	not used.
	Display next selection. Exit submenu after last selection.
	Exit submenu.

Details:

- X-Gauge S/N: Serial number of **X-Gauge** module.
- X-Gauge HWV: Hardware version of **X-Gauge** module.
- X-Gauge SWV: Software version of **X-Gauge** module.
- Vdd Display: Supply voltage provided to display of **X-Gauge** module.
- Vcc MCU: Supply voltage provided to micro controller of **X-Gauge** module.
- Clock MCU: Clock frequency of micro controller.
- Timeout Errors: Accumulated timeout errors that occurred on OBD link.
- Checksum Errors: Accumulated checksum errors that occurred on OBD link.
- Collision Errors: Accumulated collision errors that occurred on OBD link.
- ECU OBD: OBD requirements that the vehicle meets reported by ECU.
- ECU HW#: Hardware number reported by ECU.
- ECU SW#: Software number reported by ECU.
- Key Bytes: Key Bytes reported by ECU.
- PID 01-20: Encoded parameter identifications from 1 through 32 that the ECU supports according to SAE-J2178.
- PID 21-40: Encoded parameter identifications from 33 through 64 that the ECU supports according to SAE-J2178.
- PID 41-60: Encoded parameter identifications from 65 through 96 that the ECU supports according to SAE-J2178.

Notes:

- Submenu is exit if neither RBS nor LBS are pushed within 10 seconds (timeout) without resetting accumulated timeout, checksum and collision errors.
- All data presented in this submenu is intended for informational purposes only.
- Accumulated numbers for timeout, checksum and collision errors will be reset to zero when submenu is exit via RBS. They will not be reset if submenu is exit via RBL.

8.1.13 Submenu: Clear Trouble Codes

Diagnostic trouble codes that the ECU might have stored can be erased through this submenu.

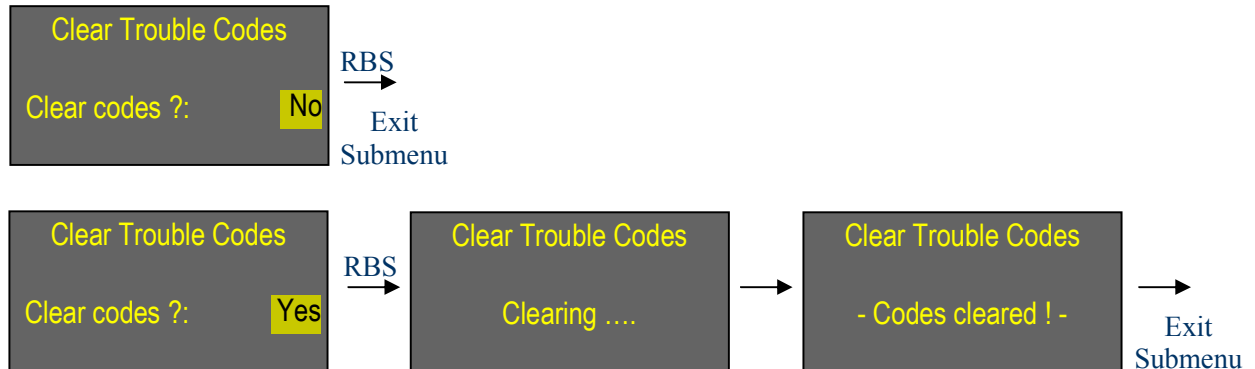

Functionality of buttons while in submenu:

	Change setting between Yes and No.
	not used.
	Accept Yes or No selection. If No, exit submenu. if Yes, start clearing codes.
	Exit submenu <u>without</u> clearing any codes.

Notes:



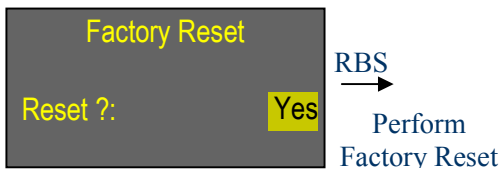

- **Because clearing of diagnostic trouble codes requires that ignition is turned on, this submenu selection does not appear while ignition is turned off! Trouble codes can be cleared with engine running or stopped.**
- Submenu is exit if neither RBS nor LBS are pushed within 10 seconds (timeout) without clearing any codes.
- Clearing of codes has to be confirmed by explicitly selecting *Yes*.
- Clearing of trouble codes will start if *Yes* is selected and RBS gets pushed. During the clearing process, an animated clearing message is shown in the center line of the display. After clearing completes successfully or if it fails for some reason, the display will show ‘- Codes cleared ! -’ or ‘- Codes NOT cleared ! -’, respectively, for the duration of 2 seconds before submenu is exit .
- Even if clearing has been confirmed with ‘- Codes cleared ! -’ trouble codes will still be displayed by the **X-Gauge** until ignition is turned off and then on again (the same is true for the check-engine symbol in the lower right corner of your instrument panel).
- Be aware that selecting *Yes* will not only erase the trouble codes but will in fact also clear other diagnostic data that the ECU might have recorded but can not be read out by the **X-Gauge**.

8.1.14 Submenu: Factory Reset

A factory reset of the **X-Gauge** can be initiated through this submenu whenever all user programmable settings should be set back to their default values.



Functionality of buttons while in submenu:

	Change setting between Yes and No.
	not used.
	Accept Yes or No selection. If No, exit submenu. if Yes, perform factory reset.
	Exit submenu <u>without</u> performing a factory reset.

Notes:

- Submenu is exit if neither RBS nor LBS are pushed within 10 seconds (timeout) without performing a factory reset.
- A factory reset has to be confirmed by explicitly selecting *Yes*.
- The result of a factory reset is the same as if the continuous 12-Volt supply is removed temporarily from the **X-Gauge** module, either by removing/reconnecting the module's 3-wire connector that is located under the center console, or by disconnecting/reconnecting the car's battery.

9 Appendices

9.1 Default Settings after a Factory Reset

All user programmed settings of the **X-Gauge** will be lost if the continuous 12-Volt supply over the 3-wire cockpit clock connector gets interrupted or if the user has acknowledged a factory reset via submenu *Factory Reset*. The table below lists the default settings that get loaded after power has been restored. These settings are, of course, also active if the **X-Gauge** is powered up for the first time after installation.

Menu Settings:

<i>Menu Setting</i>	<i>After Factory Reset</i>
Mileage Correction	0 %
Mileage Gallon	US
Mileage Average	reset
Speed Correction	0%
Maximum Speed	reset to 0 km/h
Acceleration Start Speed	60 km/h
Acceleration End Speed	80 km/h
Maximum Acceleration	reset
Turbo Ambient Pressure	0.00 bar
Turbo Cool down Time	0 s (disabled)
Turbo Cool down Time shown at	Vehicle Speed
Display Mode Display	Main
Display Mode Type	Normal
Display Mode Horizontal Flip	No
Display Mode Vertical Flip	No
Time	00:00:00
Date	Jan-01-2005
Units of Temperature	°C
Units of Pressure	bar
Units of Air Flow	g/s
Units of Speed	km/h
Units of Mileage	l/100km
Language	English
Greeting	Standard
Display Intensity Day	8
Display Intensity Night	3

Parameter Assignments for display mode ‘Main’:

<i>Display Location</i>	<i>After Factory Reset (Gasoline/Petrol Engine)</i>	<i>After Factory Reset (Diesel Engine)</i>
Top Line Left	Fuel System	Engine Load
Top Line Center	Ø-Mileage	Intake Air Temperature
Top Line Right	Coolant Temperature	Coolant Temperature
Center Line	Intake Absolute Pressure	Intake Absolute Pressure
Bottom Line Left	Battery Voltage	Battery Voltage
Bottom Line Center	Time	Time
Bottom Line Right	Inside Temperature	Inside Temperature

Active display location for changing parameter assignment: Top Line Left

Parameter Assignments for display mode ‘Text’:

<i>Display Line</i>	<i>After Factory Reset (Gasoline/Petrol Engine)</i>	<i>After Factory Reset (Diesel Engine)</i>
Line 1	Intake Absolute Pressure	Engine Load
Line 2	Engine Load	Intake Absolute Pressure
Line3	Coolant Temperature	Intake Air Temperature
Line 4	Fuel System	Coolant Temperature

Active display line for changing parameter assignment: Line 1

Parameter Assignments for display mode ‘Graphic’:

<i>Display Location</i>	<i>After Factory Reset (Gasoline/Petrol Engine)</i>	<i>After Factory Reset (Diesel Engine)</i>
Graph 1	Oxygen Sensor 1 Voltage	Engine Load
Graph 1	Oxygen Sensor 2 Voltage	Intake Absolute Pressure
Update of Graphs	On	On

Active display location for changing parameter assignment: Graph 1

9.2 FAQ

This chapter is a compilation of frequently asked **X-Gauge** related questions and their answers. You'll always find an up to date version on our website.

Q1: *Besides the fortwo, will the **X-Gauge** also work with other cars made by smart[®] or with cars made by other manufactures that feature an OBD connector?*

A1: The hardware as well as the software of the **X-Gauge** was explicitly developed for the fortwo. The **X-Gauge** will, however, also work in the smart[®] roadster since it shares its engine and ECU with the fortwo. But a solution for housing and wiring of the **X-Gauge** in a smart[®] roadster is not readily available as it is with the cockpit clock in the fortwo. Regarding any other car, it would be pure coincidence if its ECU would respond correctly to the **X-Gauge**.

Q2: *Can the **X-Gauge** be ordered together with the housing of the cockpit clock?*

A2: No, the **X-Gauge** can only be delivered as a kit. You must provide the cockpit clock yourselves. If your smart[®] is not already equipped with one, you'll either have to buy one from a smart[®] dealer or, if your lucky, you might be able to get one from a salvage yard. Only the plain case, the two plastic button plugs, the plastic screen, the decorative color ring and the 3 mounting screws are actually needed.

Q3: *Can the **X-Gauge** be installed by the average do-it-yourselfer?*

A3: Lets put it this way: if you're able to change the bulbs of your smart[®]'s driving lights yourselves, you're probably capable of installing an **X-Gauge**. Seriously, read through the entire installation guide in order to get a feeling for doing the job yourself. If you do not feel comfortable with any of the required procedures, you should have someone qualified do the job for you.

Q4: *Once the **X-Gauge** is installed, can I convert it back to the cockpit clock at a later time?*

A4: Yes, if you've kept all parts from the cockpit clock that were not needed for the **X-Gauge** conversion then you can put the clock back together at any time. No parts of the clock get altered in any way. Only the 3-wire cable that was removed from the clock module must be re-soldered.

Q5: *Does the **X-Gauge** drain my car's battery if the car is not driven for an extended period?*

A5: Not at all. When ignition is turned off, the **X-Gauge** actually draws less current from the battery than the original cockpit clock.

Q6: *Does the **X-Gauge** modify my car's ECU programming in any way?*

A6: No. All the **X-Gauge** does is sending requests to the ECU for receiving selected parameter data. If the ECU is not occupied with any higher priority tasks it will respond to such requests.

Q7: *Once the **X-Gauge** is installed, can the mechanic at the smart[®] dealership still use his diagnostic equipment on my car?*

A7: Yes. The mechanic can unplug the **X-Gauge**'s OBD connector at any time in order to connect his diagnostic equipment instead. Just make sure that the **X-Gauge**'s OBD connector gets reconnected after the mechanic has finished his diagnosis, otherwise your **X-Gauge** won't work properly anymore.

Q8: *There is a blinking dot in the top right corner of my **X-Gauge**. What is it for?*

A8: The top right pixel of the display is used as an indicator that is lit (sometimes flashing) whenever parameters are retrieved from the ECU. It stays dark when no data between the **X-Gauge** and the ECU is being exchanged (e.g. all assigned parameters of the active display mode are non-ECU parameters).

Q9: *Can I modify any engine parameters with the **X-Gauge**?*

A9: No. The **X-Gauge** is a monitoring device only.

Q10: *Since a car's OBD interface is actually intended for temporary hookup of diagnostic equipment, is it safe to have the **X-Gauge** connected continuously?*

A10: So far we have driven our test smart[®] with a connected **X-Gauge** for over 50'000 km with continuously monitoring various ECU parameters and we have not encountered any problems whatsoever. The additional processing load that the **X-Gauge** puts onto the car's ECU is insignificant as compared to the ECU's main processing tasks. Common engineering sense would also suggest that if the ECU would run into a processing bottleneck due to an OBD request from the **X-Gauge**, that this request would simply be ignored. Besides, there are commercial OBD logging devices available which also stay connected to the interface continuously. If you are still concerned, just assign all non-ECU parameters to the display mode that you use for daily driving. That way no communications will take place over the OBD interface.

Q11: *Why doesn't the **X-Gauge** work in smart[®] models before 2001 (Gasoline/Petrol) or before 2004 (Diesel)?*

A11: The diagnostic interface in smart[®] cars before model year 2001 (Gasoline/Petrol) or before 2004 (Diesel) simply does not deliver the generic engine parameters that the **X-Gauge** requests from the ECU. This feature has been added to the ECU starting with model year 2001/2004.

Q12: *How does the absolute intake pressure that the **X-Gauge** displays relate to the actual turbo pressure (boost)?*

A12: The **X-Gauge** displays ABSOLUTE intake pressure that the ECU reports from the engine's MAP (Manifold Absolute Pressure) sensor. All the ECU is interested in is absolute Pressure. RELATIVE intake pressure (boost or vacuum), the one that you are rather interested in, is given by:

Relative pressure (boost or vacuum) = Absolute pressure - Ambient pressure
(Ambient pressure is nominally 1 bar (14.5 psi) at sea level)

The following examples assume an ambient pressure of 1 bar (adjust for other heights above sea level):

X-Gauge Display	Relative Boost or Vacuum
0.50 bar	-0.50 bar (vacuum)
1.00 bar	0.00 bar (neither vacuum nor boost)
1.50 bar	0.50 bar (boost)
2.55 bar	1.55 bar (maximal boost that the ECU will report)

A fixed ambient pressure can be set via the user menu so that the **X-Gauge** will display a relative intake pressure (negative values for vacuum, positive values for boost). Ambient pressure is, however, dependent on altitude, temperature and weather conditions so that the relative pressure display can only be accurate within these limitations.

Q13: *Why isn't the X-Gauge compatible with smart® models after 2006 (fortwo 451)?*

A13: Starting with model year 2007 (fortwo 451), smart® has changed to a newly mandated OBD protocol (CAN-Bus) that the X-Gauge has not implemented. In addition, the clock pod itself is different and will not accommodate the PCB of the current X-Gauge hardware.

9.3 Troubleshooting

Before returning a suspected malfunctioning **X-Gauge** for repair please check through the following symptoms and their possible remedies.

<i>Symptom</i>	<i>Possible Fix</i>
<p>X-Gauge does not turn on if either left or right button is pushed while ignition is OFF.</p>	<p>Make sure that the 3-wire PCB connector of the X-Gauge that is located under the center console is correctly inserted. Even if so, remove the connector and reinsert it which will cause a factory reset of the X-Gauge.</p> <p>You can also cause a factory reset of the X-Gauge by detaching the negative battery cable of the car for a few seconds and then reconnect it. Be aware, though, that this may also reset your radio and you might have to re-enter the security code of the radio !</p> <p>If your car's horn is not working at the same time, check Fuse #16 (see your car's user manual).</p> <p>Verify that none of the wires at the X-Gauge module are broken off.</p> <p>Verify that the flat cable of the display assembly is securely seated in its connector.</p>
<p>X-Gauge does turn on temporarily for 30 seconds if either left or right button is pushed while ignition is OFF, but it does NOT turn on when ignition is ON.</p>	<p>Underneath your dash, make sure that the two OBD wires of the X-Gauge are inserted properly into the OBD connector shell and that this shell is seated correctly into the car's OBD socket.</p> <p>If your car's radio is not working at the same time, check Fuse #11 (see your car's user manual).</p> <p>Verify that none of the wires at the X-Gauge module are broken off.</p>
<p>X-Gauge does turn on when ignition is ON and all non-ECU parameters (Time, Date, Battery Voltage, Inside Temperature) are shown correctly, but data of all ECU parameters are not displayed.</p>	<p>Push RBL which will enter Main Menu. Wait until Main Menu exits itself by timeout (10 seconds).</p> <p><i>If problem still exist:</i> Turn ignition off for approximately 30 seconds and then back on again.</p> <p><i>If problem still exist:</i> Underneath your dash, make sure that the two OBD wires of the X-Gauge are inserted</p>

	<p>properly into the OBD connector shell and that this shell is seated correctly into the car's OBD socket.</p> <p><i>If problem still exist:</i> Verify that none of the wires at the X-Gauge module are broken off.</p>
--	--